

COMMISSION REGULATION (EU) No 1152/2010

of 8 December 2010

amending, for the purpose of its adaptation to technical progress, Regulation (EC) No 440/2008 laying down test methods pursuant to Regulation (EC) No 1907/2006 of the European Parliament and of the Council on the Registration, Evaluation, Authorisation and Restriction of Chemicals (REACH)

(Text with EEA relevance)

THE EUROPEAN COMMISSION,

Having regard to the Treaty on the Functioning of the European Union,

Having regard to Regulation (EC) No 1907/2006 of 18 December 2006 of the European Parliament and of the Council concerning the Registration, Evaluation, Authorisation and Restriction of Chemicals (REACH), establishing a European Chemicals Agency, amending Directive 1999/45/EC and repealing Council Regulation (EEC) No 793/93 and Commission Regulation (EC) No 1488/94 as well as Council Directive 76/769/EEC and Commission Directives 91/155/EEC, 93/67/EEC, 93/105/EC and 2000/21/EC⁽¹⁾, and in particular Article 13(3) thereof,

Whereas:

- (1) Commission Regulation (EC) No 440/2008⁽²⁾ contains the test methods for the purposes of the determination of the physico-chemical properties, toxicity and eco-toxicity of substances to be applied for the purposes of Regulation (EC) No 1907/2006.
- (2) It is necessary to update Regulation (EC) No 440/2008 to include with priority two new in vitro test methods for ocular irritation recently adopted by the OECD, in order to obtain a reduction of the number of animals to be used for experimental purposes, in accordance with

Council Directive 86/609/EEC of 24 November 1986 on the approximation of laws, regulations and administrative provisions of the Member States regarding the protection of animals used for experimental and other scientific purposes⁽³⁾. Stakeholders have been consulted on this draft.

- (3) Regulation (EC) No 440/2008 should therefore be amended accordingly.
- (4) The measures provided for in this Regulation are in accordance with the opinion of the Committee established under Article 133 of Regulation (EC) No 1907/2006,

HAS ADOPTED THIS REGULATION:

Article 1

In Part B of the Annex to Regulation (EC) No 440/2008, Chapters B.47 and B.48 are added as set out in the Annex to this Regulation.

Article 2

This Regulation shall enter into force on the third day following that of its publication in the *Official Journal of the European Union*.

This Regulation shall be binding in its entirety and directly applicable in all Member States.

Done at Brussels, 8 December 2010.

For the Commission
The President
José Manuel BARROSO

⁽¹⁾ OJ L 396, 30.12.2006, p. 1.

⁽²⁾ OJ L 142, 31.5.2008, p. 1.

⁽³⁾ OJ L 358, 18.12.1986, p. 1.

ANNEX

B. 47. BOVINE CORNEAL OPACITY AND PERMEABILITY TEST METHOD FOR IDENTIFYING OCULAR CORROSIVES AND SEVERE IRRITANTS

INTRODUCTION

1. The Bovine Corneal Opacity and Permeability (BCOP) test method is an *in vitro* test method that can be used, under certain circumstances and with specific limitations, to classify substances and mixtures as “ocular corrosives and severe irritants” (1) (2) (3). For the purpose of this test method, severe irritants are defined as those that induce ocular lesions that persist in the rabbit for at least 21 days after administration. While it is not considered valid as a complete replacement for the *in vivo* rabbit eye test, the BCOP is recommended for use as part of a tiered-testing strategy for regulatory classification and labelling within a specific applicability domain (4) (5). Test substances and mixtures (6) can be classified as ocular corrosives or severe irritants without further testing in rabbits. A substance that tests negative would need to be tested in rabbits using a sequential testing strategy, as outlined in OECD Test Guideline 405 (7) (chapter B. 5 of this Annex).
2. The purpose of this test method is to describe the procedures used to evaluate the potential ocular corrosivity or severe irritancy of a test substance as measured by its ability to induce opacity and increased permeability in an isolated bovine cornea. Toxic effects to the cornea are measured by: (i) decreased light transmission (opacity), and (ii) increased passage of sodium fluorescein dye (permeability). The opacity and permeability assessments of the cornea following exposure to a test substance are combined to derive an *In Vitro* Irritancy Score (IVIS), which is used to classify the irritancy level of the test substance.
3. Ocular irritants that induce lesions that resolve in less than 21 days and non-irritants have also been tested using the BCOP test method. However, the accuracy and reliability of the BCOP test method for substances in these categories have not been formally evaluated.
4. Definitions are provided in Appendix 1.

INITIAL CONSIDERATIONS AND LIMITATIONS

5. This test method is based on the Interagency Coordinating Committee on the Validation of Alternative Methods (ICCVAM) BCOP test method protocol (8), which was developed following an international validation study (4)(5)(9), with contributions from the European Centre for the Validation of Alternative Methods (ECVAM) and the Japanese Center for the Validation of Alternative Methods (JaCVAM). The protocol is based on information obtained from the Institute for In Vitro Sciences (IIVS) and INVITOX Protocol 124 (10), which represents the protocol used for the European Community-sponsored prevalidation study of the BCOP assay conducted in 1997-1998. Both of these protocols are based on the BCOP assay methodology first reported by Gautheron *et al.* (11).
6. The identified limitations for this test method are based on the high false positive rates for alcohols and ketones and the high false negative rate for solids observed in the validation database (see paragraph 44) (5). When substances within these chemical and physical classes are excluded from the database, the accuracy of BCOP across the EU, EPA, and GHS classification systems is substantially improved (5). Based on the purpose of this assay (*i.e.*, to identify ocular corrosives/severe irritants only), false negative rates are not critical since such substances would be subsequently tested in rabbits or with other adequately validated *in vitro* tests, depending on regulatory requirements, using a sequential testing strategy in a weight of evidence approach. Furthermore, the current validation database did not allow for an adequate evaluation of some chemical or product classes (*e.g.*, mixtures). However, investigators could consider using this test method for all types of test material (including mixtures), whereby a positive result could be accepted as indicative of an ocular corrosive or severe irritant response. However, positive results obtained with alcohols or ketones should be interpreted cautiously due to risk of over-prediction.
7. All procedures with bovine eyes and bovine corneas should follow the testing facility's applicable regulations and procedures for handling animal-derived materials, which include, but are not limited to, tissues and tissue fluids. Universal laboratory precautions are recommended (12).
8. A limitation of the test method is that, although it takes into account some of the ocular effects evaluated in the rabbit ocular irritancy test method and to some degree their severity, it does not consider conjunctival and iridal injuries. Also, although the reversibility of corneal lesions cannot be evaluated *per se* in the BCOP assay, it has been proposed, based on rabbit eye studies, that an assessment of the initial depth of corneal injury can be used to distinguish between irreversible and reversible effects (13). Finally, the BCOP does not allow for an assessment of the potential for systemic toxicity associated with ocular exposure.

9. Efforts are ongoing to further characterize the usefulness and limitations of the BCOP assay for identifying non-severe irritants and non-irritants (see also paragraph 45). Users are also encouraged to provide specimens and/or data to validation organizations for a formal evaluation of possible future uses of the BCOP test method, including for the identification of non-severe irritants and non-irritants.
10. For any laboratory initially establishing this assay, the proficiency chemicals provided in Appendix 2 should be used. A laboratory can use these chemicals to demonstrate their technical competence in performing the BCOP test method prior to submitting BCOP assay data for regulatory hazard classification purposes.

PRINCIPLE OF THE TEST

11. The BCOP test method is an organotypic model that provides short-term maintenance of normal physiological and biochemical function of the bovine cornea *in vitro*. In this test method, damage by the test substance is assessed by quantitative measurements of changes in corneal opacity and permeability with an opacitometer and a visible light spectrophotometer, respectively. Both measurements are used to calculate an IVIS, which is used to assign an *in vitro* irritancy hazard classification category for prediction of the *in vivo* ocular irritation potential of a test substance (see Decision criteria).
12. The BCOP test method uses isolated corneas from the eyes of freshly slaughtered cattle. Corneal opacity is measured quantitatively as the amount of light transmission through the cornea. Permeability is measured quantitatively as the amount of sodium fluorescein dye that passes across the full thickness of the cornea, as detected in the medium in the posterior chamber. Test substances are applied to the epithelial surface of the cornea by addition to the anterior chamber of the corneal holder. Appendix 3 provides a description and a diagram of a corneal holder used in the BCOP. Corneal holders can be obtained commercially from different sources or can be constructed.

Source and Age of Bovine Eyes and Selection of Animal Species

13. Cattle sent to slaughterhouses are typically killed either for human consumption or for other commercial uses. Only healthy animals considered suitable for entry into the human food chain are used as a source of corneas for use in the BCOP. Because cattle have a wide range of weights, depending on breed, age, and sex, there is no recommended weight for the animal at the time of slaughter.
14. Variations in corneal dimensions can result when using eyes from animals of different ages. Corneas with a horizontal diameter $> 30,5$ mm and central corneal thickness (CCT) values $\geq 1\ 100$ μm are generally obtained from cattle older than eight years, while those with a horizontal diameter $< 28,5$ mm and CCT < 900 μm are generally obtained from cattle less than five years old (14). For this reason, eyes from cattle greater than 60 months old are not typically used. Eyes from cattle less than 12 months of age have not traditionally been used since the eyes are still developing and the corneal thickness and corneal diameter are considerably smaller than that reported for eyes from adult cattle. However, the use of corneas from young animals (*i.e.*, 6 to 12 months old) is permissible since there are some advantages, such as increased availability, a narrow age range, and decreased hazards related to potential worker exposure to Bovine Spongiform Encephalopathy (15). As further evaluation of the effect of corneal size or thickness on responsiveness to corrosive and irritant substances would be useful, users are encouraged to report the estimated age and/or weight of the animals providing the corneas used in a study.

Collection and Transport of Eyes to the Laboratory

15. Eyes are collected by slaughterhouse employees. To minimize mechanical and other types of damage to the eyes, the eyes should be enucleated as soon as possible after death. To prevent exposure of the eyes to potentially irritant substances, the slaughterhouse employees should not use detergent when rinsing the head of the animal.
16. Eyes should be immersed completely in Hanks' Balanced Salt Solution (HBSS) in a suitably sized container, and transported to the laboratory in such a manner as to minimize deterioration and/or bacterial contamination. Because the eyes are collected during the slaughter process, they might be exposed to blood and other biological substances, including bacteria and other microorganisms. Therefore, it is important to ensure that the risk of contamination is minimized (*e.g.*, by keeping the container containing the eyes on wet ice, by adding antibiotics to the HBSS used to store the eyes during transport [*e.g.*, penicillin at 100 IU/mL and streptomycin at 100 $\mu\text{g}/\text{mL}$]).
17. The time interval between collection of the eyes and use of corneas in the BCOP should be minimized (typically collected and used on the same day) and should be demonstrated to not compromise the assay results. These results are based on the selection criteria for the eyes, as well as the positive and negative control responses. All eyes used in the assay should be from the same group of eyes collected on a specific day.

Selection Criteria for Eyes Used in the BCOP

18. The eyes, once they arrive at the laboratory, are carefully examined for defects including increased opacity, scratches, and neovascularisation. Only corneas from eyes free of such defects are to be used.
19. The quality of each cornea is also evaluated at later steps in the assay. Corneas that have an opacity greater than seven opacity units (NOTE: the opacitometer should be calibrated with opacity standards that are used to establish the opacity units, see Appendix 3) after an initial one hour equilibration period are to be discarded.
20. Each treatment group (test substance, concurrent negative and positive controls) consists of a minimum of three eyes. Three corneas should be used for the negative control corneas in the BCOP assay. Since all corneas are excised from the whole globe, and mounted in the corneal chambers, there is the potential for artefacts from handling upon individual corneal opacity and permeability values (including negative control). Furthermore, the opacity and permeability values from the negative control corneas are used to correct the test article and positive control-treated corneal opacity and permeability values in the IVIS calculations.

PROCEDURE

Preparation of the Eyes

21. Corneas free of defects are dissected with a 2 to 3 mm rim of sclera remaining to assist in subsequent handling, with care taken to avoid damage to the corneal epithelium and endothelium. Isolated corneas are mounted in specially designed corneal holders that consist of anterior and posterior compartments, which interface with the epithelial and endothelial sides of the cornea, respectively. Both chambers are filled to excess with pre-warmed Eagle's Minimum Essential Medium (EMEM) (posterior chamber first), ensuring that no bubbles are formed. The device is then equilibrated at 32 ± 1 °C for at least one hour to allow the corneas to equilibrate with the medium and to achieve normal metabolic activity, to the extent possible (the approximate temperature of the corneal surface *in vivo* is 32 °C).
22. Following the equilibration period, fresh pre-warmed EMEM is added to both chambers and baseline opacity readings are taken for each cornea. Any corneas that show macroscopic tissue damage (e.g., scratches, pigmentation, neovascularisation) or an opacity > 7 opacity units are discarded. The mean opacity of all equilibrated corneas is calculated. A minimum of three corneas with opacity values close to the median value for all corneas are selected as negative (or solvent) control corneas. The remaining corneas are then distributed into treatment and positive control groups.
23. Because the heat capacity of water is higher than that of air, water provides more stable temperature conditions for incubation. Therefore, the use a water bath for maintaining the corneal holder and its contents at 32 ± 1 °C is recommended. However, air incubators might also be used, assuming precaution to maintain temperature stability (e.g., by pre-warming of holders and media).

Application of the Test Substance

24. Two different treatment protocols are used, one for liquids and surfactants (solids or liquids), and one for non-surfactant solids.
25. Liquids are tested undiluted, while surfactants are tested at a concentration of 10 % w/v in a 0,9 % sodium chloride solution, distilled water, or other solvent that has been demonstrated to have no adverse effects on the test system. Semi-solids, creams, and waxes are typically tested as liquids. Appropriate justification should be provided for alternative dilution concentrations. Corneas are exposed to liquids and surfactants for 10 minutes. Use of other exposure times should be accompanied by adequate scientific rationale.
26. Non-surfactant solids are typically tested as solutions or suspensions at 20 % concentration in a 0,9 % sodium chloride solution, distilled water, or other solvent that has been demonstrated to have no adverse effects on the test system. In certain circumstances and with proper scientific justification, solids may also be tested neat by direct application onto the corneal surface using the open chamber method (see paragraph 29). Corneas are exposed to solids for four hours, but as with liquids and surfactants, alternative exposure times may be used with appropriate scientific rationale.
27. Different treatment methods can be used, depending on the physical nature and chemical characteristics (e.g., solids, liquids, viscous vs. non-viscous liquids) of the test substance. The critical factor is ensuring that the test substance adequately covers the epithelial surface and that it is adequately removed during the rinsing steps. A closed-chamber method is typically used for non-viscous to slightly viscous liquid test substances, while an open-chamber method is typically used for semi-viscous and viscous liquid test substances and for neat solids.

28. In the closed-chamber method, sufficient test substance (750 µL) to cover the epithelial side of the cornea is introduced into the anterior chamber through the dosing holes on the top surface of the chamber, and the holes are subsequently sealed with the chamber plugs during the exposure. It is important to ensure that each cornea is exposed to a test substance for the appropriate time interval.
29. In the open-chamber method, the window-locking ring and glass window from the anterior chamber are removed prior to treatment. The control or test substance (750 µL, or enough test substance to completely cover the cornea) is applied directly to the epithelial surface of the cornea using a micropipette. If a test substance is difficult to pipette, the test substance can be pressure-loaded into a positive displacement pipette to aid in dosing. The pipette tip of the positive displacement pipette is inserted into the dispensing tip of the syringe so that the material can be loaded into the displacement tip under pressure. Simultaneously, the syringe plunger is depressed as the pipette piston is drawn upwards. If air bubbles appear in the pipette tip, the test article is removed (expelled) and the process repeated until the tip is filled without air bubbles. If necessary, a normal syringe (without a needle) can be used since it permits measuring an accurate volume of test substance and an easier application to the epithelial surface of the cornea. After dosing, the glass window is replaced on the anterior chamber to recreate a closed system.

Post-Exposure Incubation

30. After the exposure period, the test substance, the negative control, or the positive control substance is removed from the anterior chamber and the epithelium washed at least three times (or until no visual evidence of test substance can be observed) with EMEM (containing phenol red). Phenol red-containing medium is used for rinsing since a colour change in the phenol red may be monitored to determine the effectiveness of rinsing acidic or alkaline materials. The corneas are washed more than three times if the phenol red is still discoloured (yellow or purple), or the test substance is still visible. Once the medium is free of test substance, the corneas are given a final rinse with EMEM (without phenol red). The EMEM (without phenol red) is used as a final rinse to ensure removal of the phenol red from the anterior chamber prior to the opacity measurement. The anterior chamber is then refilled with fresh EMEM without phenol red.
31. For liquids or surfactants, after rinsing, the corneas are incubated for an additional two hours at 32 ± 1 °C. Longer post-exposure time may be useful in certain circumstances and could be considered on a case-by-case basis. Corneas treated with solids are rinsed thoroughly at the end of the four-hour exposure period, but do not require further incubation.
32. At the end of the post-exposure incubation period for liquids and surfactants and at the end of the four-hour exposure period for non-surfactant solids, the opacity and permeability of each cornea are recorded. Also, each cornea is observed visually and pertinent observations recorded (e.g., tissue peeling, residual test substance, non-uniform opacity patterns). These observations could be important as they may be reflected by variations in the opacitometer readings.

Control Substances

33. Concurrent negative or solvent/vehicle controls and positive controls are included in each experiment.
34. When testing a liquid substance at 100 %, a concurrent negative control (e.g., 0,9 % sodium chloride solution or distilled water) is included in the BCOP test method so that nonspecific changes in the test system can be detected and to provide a baseline for the assay endpoints. It also ensures that the assay conditions do not inappropriately result in an irritant response.
35. When testing a diluted liquid, surfactant, or solid, a concurrent solvent/vehicle control group is included in the BCOP test method so that nonspecific changes in the test system can be detected and to provide a baseline for the assay endpoints. Only a solvent/vehicle that has been demonstrated to have no adverse effects on the test system can be used.
36. A known ocular irritant is included as a concurrent positive control in each experiment to verify that an appropriate response is induced. As the BCOP assay is being used in this test method to identify corrosive or severe irritants, ideally the positive control should be a reference substance that induces a severe response in this test method. However, to ensure that variability in the positive control response across time can be assessed, the magnitude of irritant response should not be excessive.
37. Examples of positive controls for liquid test substances are dimethylformamide or 1 % sodium hydroxide. An example of a positive control for solid test substances is 20 % (weight to volume) imidazole in 0,9 % sodium chloride solution.

38. Benchmark substances are useful for evaluating the ocular irritancy potential of unknown chemicals of a specific chemical or product class, or for evaluating the relative irritancy potential of an ocular irritant within a specific range of irritant responses.

Endpoints Measured

39. Opacity is determined by the amount of light transmission through the cornea. Corneal opacity is measured quantitatively with the aid of an opacitometer, resulting in opacity values measured on a continuous scale.
40. Permeability is determined by the amount of sodium fluorescein dye that penetrates all corneal cell layers (*i.e.*, the epithelium on the outer cornea surface through the endothelium on the inner cornea surface). 1 mL sodium fluorescein solution (4 or 5 mg/mL when testing liquids and surfactants or non-surfactant solids, respectively) is added to the anterior chamber of the corneal holder, which interfaces with the epithelial side of the cornea, while the posterior chamber, which interfaces with the endothelial side of the cornea, is filled with fresh EMEM. The holder is then incubated in a horizontal position for 90 ± 5 min at 32 ± 1 °C. The amount of sodium fluorescein that crosses into the posterior chamber is quantitatively measured with the aid of UV/VIS spectrophotometry. Spectrophotometric measurements evaluated at 490 nm are recorded as optical density (OD₄₉₀) or absorbance values, which are measured on a continuous scale. The fluorescein permeability values are determined using OD₄₉₀ values based upon a visible light spectrophotometer using a standard 1 cm path length.
41. Alternatively, a 96-well microtiter plate reader may be used provided that; (i) the linear range of the plate reader for determining fluorescein OD₄₉₀ values can be established; and (ii), the correct volume of fluorescein samples are used in the 96-well plate to result in OD₄₉₀ values equivalent to the standard 1 cm path length (this could require a completely full well [usually 360 µL]).

DATA AND REPORTING

Data Evaluation

42. Once the opacity and mean permeability (OD₄₉₀) values have been corrected for background opacity and the negative control permeability OD₄₉₀ values, the mean opacity and permeability OD₄₉₀ values for each treatment group should be combined in an empirically-derived formula to calculate an *in vitro* irritancy score (IVIS) for each treatment group as follows:

$$\text{IVIS} = \text{mean opacity value} + (15 \times \text{mean permeability OD}_{490} \text{ value})$$

Sina *et al.* (16) reported that this formula was derived during in-house and inter-laboratory studies. The data generated for a series of 36 compounds in a multi-laboratory study were subjected to a multivariate analysis to determine the equation of best fit between *in vivo* and *in vitro* data. This analysis was performed by scientists at two separate companies, who derived nearly identical equations.

43. The opacity and permeability values should also be evaluated independently to determine whether a test substance induced corrosivity or severe irritation through only one of the two endpoints (see Decision Criteria).

Decision Criteria

44. A substance that induces an IVIS $\geq 55,1$ is defined as a corrosive or severe irritant. As stated in paragraph 1, if the test substance is not identified as an ocular corrosive or severe irritant, additional testing should be conducted for classification and labelling purposes. The BCOP test method has an overall accuracy of 79 % (113/143) to 81 % (119/147), a false positive rate of 19 % (20/103) to 21 % (22/103), and a false negative rate of 16 % (7/43) to 25 % (10/40), when compared to *in vivo* rabbit eye test method data classified according to the EPA (1), EU (2), or GHS (3) classification systems. When substances within certain chemical (*i.e.*, alcohols, ketones) or physical (*i.e.*, solids) classes are excluded from the database, the accuracy of BCOP across the EU, EPA, and GHS classification systems ranges from 87 % (72/83) to 92 % (78/85), the false positive rates range from 12 % (7/58) to 16 % (9/56), and the false negative rates range from 0 % (0/27) to 12 % (3/26).
45. Even if an ocular corrosive or severe irritant classification is not obtained for a test substance, BCOP data can be useful, in conjunction with test data from the *in vivo* rabbit eye test or from an adequately validated *in vitro* test, to further evaluate the usefulness and limitations of the BCOP test method for identifying non-severe irritants and non-irritants (a Guidance Document on the use of *in vitro* ocular toxicity test methods is under development).

Study Acceptance Criteria

46. A test is considered acceptable if the positive control gives an IVIS that falls within two standard deviations of the current historical mean, which is to be updated at least every three months, or each time an acceptable test is conducted in laboratories where tests are conducted infrequently (*i.e.*, less than once a month). The negative or solvent/vehicle control responses should result in opacity and permeability values that are less than the established upper limits for background opacity and permeability values for bovine corneas treated with the respective negative or solvent/vehicle control.

Test Report

47. The test report should include the following information, if relevant to the conduct of the study:

Test and Control Substances

Chemical name(s) such as the structural name used by the Chemical Abstracts Service (CAS), followed by other names, if known;

The CAS Registry Number (RN), if known;

Purity and composition of the substance or mixture (in percentage(s) by weight), to the extent this information is available;

Physicochemical properties such as physical state, volatility, pH, stability, chemical class, water solubility relevant to the conduct of the study;

Treatment of the test/control substances prior to testing, if applicable (*e.g.*, warming, grinding);

Stability, if known.

Information Concerning the Sponsor and the Test Facility

Name and address of the sponsor, test facility and study director;

Identification of the source of the eyes (*i.e.*, the facility from which they were collected);

Storage and transport conditions of eyes (*e.g.*, date and time of eye collection, time interval prior to initiating testing, transport media and temperature conditions, any antibiotics used);

If available, specific characteristics of the animals from which the eyes were collected (*e.g.*, age, sex, weight of the donor animal).

*Justification of the Test Method and Protocol Used**Test Method Integrity*

The procedure used to ensure the integrity (*i.e.*, accuracy and reliability) of the test method over time (*e.g.*, periodic testing of proficiency substances, use of historical negative and positive control data).

Criteria for an Acceptable Test

Acceptable concurrent positive and negative control ranges based on historical data;

If applicable, acceptable concurrent benchmark control ranges based on historical data.

Test Conditions

Description of test system used;

Type of corneal holder used;

Calibration information for devices used for measuring opacity and permeability (*e.g.*, opacitometer and spectrophotometer);

Information on the bovine corneas used, including statements regarding their quality;

Details of test procedure used;

Test substance concentration(s) used;

Description of any modifications of the test procedure;

Reference to historical data of the model (e.g., negative and positive controls, proficiency substances, benchmark substances);

Description of evaluation criteria used.

Results

Tabulation of data from individual test samples (e.g., opacity and OD₄₉₀ values and calculated IVIS for the test substance and the positive, negative, and benchmark controls [if included], reported in tabular form, including data from replicate repeat experiments as appropriate, and means ± the standard deviation for each experiment);

Description of other effects observed.

Discussion of the Results

Conclusion

LITERATURE

(1) U.S. EPA (1996). Label Review Manual: 2nd Edition. EPA737-B-96-001. Washington, DC: U.S. Environmental Protection Agency.

(2) Regulation (EC) No 1272/2008 of the European Parliament and of the Council of 16 December 2008 on classification, labelling and packaging of substances and mixtures, amending and repealing Directive 67/548/EEC and 1999/45/EC, and amending Regulation (EC) No 1907/2006. OJ L 353, 31.12.2008, p. 1.

(3) UN (2007). Globally Harmonized System of Classification and Labelling of Chemicals (GHS). Second revised edition, New York & Geneva: United Nations Publications, 2007. Available:

[http://www.unece.org/trans/danger/publi/ghs/ghs_rev02/02files_e.html]

(4) ESAC (2007). Statement on the conclusion of the ICCVAM retrospective study on organotypic *in vitro* assays as screening tests to identify potential ocular corrosives and severe eye irritants. Available:

[<http://ecvam.jrc.it/index.htm>]

(5) ICCVAM (2007). Test Method Evaluation Report - *In Vitro* Ocular Toxicity Test Methods for Identifying Ocular Severe Irritants and Corrosives. Interagency Coordinating Committee on the Validation of Alternative Methods (ICCVAM) and the National Toxicology Program (NTP) Interagency Center for the Evaluation of Alternative Toxicological Methods (NICEATM). NIH Publication No: 07-4517. Available:

[http://iccvam.niehs.nih.gov/methods/ocutox/ivocutox/ocu_tmter.htm]

(6) Regulation (EC) No 1907/2006 of the European Parliament and of the Council of 18 December 2006 concerning the Registration, Evaluation, Authorisation and Restriction of Chemicals (REACH), establishing a European Chemicals Agency, amending Directive 1999/45/EC and repealing Council Regulation (EEC) No 793/93 and Commission Regulation (EC) No 1488/94 as well as Council Directive 76/769/EEC and Commission Directives 91/155/EEC, 93/67/EEC, 93/105/EC and 2000/21/EC. OJ L 396, 30.12.2006, p. 1.

(7) OECD (2002). Test Guideline 405. OECD Guideline for Testing of Chemicals. Acute eye irritation/corrosion. Available:

[http://www.oecd.org/document/40/0,2340,en_2649_34377_37051368_1_1_1_1,00.html]

- (8) ICCVAM (2007). ICCVAM Recommended BCOP Test Method Protocol. In: ICCVAM Test Method Evaluation Report - *In Vitro* Ocular Toxicity Test Methods for Identifying Ocular Severe Irritants and Corrosives. Inter-agency Coordinating Committee on the Validation of Alternative Methods (ICCVAM) and the National Toxicology Program (NTP) Interagency Center for the Evaluation of Alternative Toxicological Methods (NICEATM). NIH Publication No: 07-4517. Available:
- [http://iccvam.niehs.nih.gov/methods/ocutox/ivocutox/ocu_tmer.htm]
- (9) ICCVAM. (2006). Current Status of *In Vitro* Test Methods for Identifying Ocular Corrosives and Severe Irritants: Bovine Corneal Opacity and Permeability Test Method. NIH Publication No: 06-4512. Research Triangle Park: National Toxicology Program. Available:
- [http://iccvam.niehs.nih.gov/methods/ocutox/ivocutox/ocu_brd_ice.htm]
- (10) INVITTOX (1999). Protocol 124: Bovine Corneal Opacity and Permeability Assay – SOP of Microbiological Associates Ltd. Ispra, Italy: European Centre for the Validation of Alternative Methods (ECVAM).
- (11) Gautheron, P., Dukic, M., Alix, D. and Sina, J.F. (1992). Bovine corneal opacity and permeability test: An *in vitro* assay of ocular irritancy. *Fundam. Appl. Toxicol.* 18:442-449.
- (12) Siegel, J.D., Rhinehart, E., Jackson, M., Chiarello, L., and the Healthcare Infection Control Practices Advisory Committee (2007). Guideline for Isolation Precautions: Preventing Transmission of Infectious Agents in Healthcare Settings. Available:
- [<http://www.cdc.gov/ncidod/dhqp/pdf>].
- (13) Maurer, J.K., Parker, R.D. and Jester, J.V. (2002). Extent of corneal injury as the mechanistic basis for ocular irritation: key findings and recommendations for the development of alternative assays. *Reg. Tox. Pharmacol.* 36:106-117.
- (14) Doughty, M.J., Petrou, S. and Macmillan, H. (1995). Anatomy and morphology of the cornea of bovine eyes from a slaughterhouse. *Can. J. Zool.* 73:2159-2165.
- (15) Collee, J. and Bradley, R. (1997). BSE: A decade on - Part I. *The Lancet* 349: 636-641.
- (16) Sina, J.F., Galer, D.M., Sussman, R.S., Gautheron, P.D., Sargent, E.V., Leong, B., Shah, P.V., Curren, R.D., and Miller, K. (1995). A collaborative evaluation of seven alternatives to the Draize eye irritation test using pharmaceutical intermediates. *Fundam Appl Toxicol* 26:20-31.
- (17) ICCVAM (2006). Background review document, Current Status of *In Vitro* Test Methods for Identifying Ocular Corrosives and Severe Irritants: Bovine Corneal Opacity and Permeability (BCOP) Test Method. Available:
- [http://iccvam.niehs.nih.gov/methods/ocutox/ivocutox/ocu_brd_bcop.htm]
- (18) ICCVAM (2006). Background review document, Current Status of *In Vitro* Test Methods for Identifying Ocular Corrosives and Severe Irritants: Isolated Chicken Eye (ICE) Test Method. Available:
- [http://iccvam.niehs.nih.gov/methods/ocutox/ivocutox/ocu_brd_bcop.htm]

Appendix 1

DEFINITIONS

Accuracy: The closeness of agreement between test method results and accepted reference values. It is a measure of test method performance and one aspect of 'relevance'. The term is often used interchangeably with 'concordance', to mean the proportion of correct outcomes of a test method.

Benchmark substance: A substance used as a standard for comparison to a test substance. A benchmark substance should have the following properties; (i) a consistent and reliable source(s); (ii) structural and functional similarity to the class of substances being tested; (iii) known physical/chemical characteristics; (iv) supporting data on known effects, and (v) known potency in the range of the desired response.

Cornea: The transparent part of the front of the eyeball that covers the iris and pupil and admits light to the interior.

Corneal opacity: Measurement of the extent of opaqueness of the cornea following exposure to a test substance. Increased corneal opacity is indicative of damage to the cornea. Opacity can be evaluated subjectively as done in the Draize rabbit eye test, or objectively with an instrument such as an 'opacitometer'.

Corneal permeability: Quantitative measurement of damage to the corneal epithelium by a determination of the amount of sodium fluorescein dye that passes through all corneal cell layers.

EPA Category 1: Corrosive (irreversible destruction of ocular tissue) or corneal involvement or irritation persisting for more than 21 days (1).

EU Category R41: Production of tissue damage in the eye, or serious physical decay of vision, following application of a test substance to the anterior surface of the eye, which is not fully reversible within 21 days of application (2).

False negative rate: The proportion of all positive substances falsely identified by a test method as negative. It is one indicator of test method performance.

False positive rate: The proportion of all negative substances that are falsely identified by a test method as positive. It is one indicator of test method performance.

GHS (Globally Harmonized System of Classification and Labelling of Chemicals): A system proposing the classification of chemicals (substances and mixtures) according to standardized types and levels of physical, health and environmental hazards, and addressing corresponding communication elements, such as pictograms, signal words, hazard statements, precautionary statements and safety data sheets, so that to convey information on their adverse effects with a view to protect people (including employers, workers, transporters, consumers and emergency responders) and the environment (3).

GHS Category 1: Production of tissue damage in the eye, or serious physical decay of vision, following application of a test substance to the anterior surface of the eye, which is not fully reversible within 21 days of application (3).

Hazard: Inherent property of an agent or situation having the potential to cause adverse effects when an organism, system or (sub) population is exposed to that agent.

In Vitro Irritancy Score (IVIS): An empirically-derived formula used in the BCOP assay whereby the mean opacity and mean permeability values for each treatment group are combined into a single *in vitro* score for each treatment group. The IVIS = mean opacity value + (15 × mean permeability value).

Negative control: An untreated replicate containing all components of a test system. This sample is processed with test substance-treated samples and other control samples to determine whether the solvent interacts with the test system.

Non-irritant: Substances that are not classified as EPA Category I, II, or III; EU Category R41 or R36; or GHS Category 1, 2A, or 2B ocular irritants.

Ocular corrosive: (a) A substance that causes irreversible tissue damage to the eye; (b) Substances that are classified as GHS Category 1, EPA Category I, or EU Category R41 ocular irritants (1) (2) (3).

Ocular irritant: (a) A substance that produces a reversible change in the eye following application to the anterior surface of the eye; (b) Substances that are classified as EPA Category II or III, EU Category R36, or GHS Category 2A or 2B ocular irritants (1) (2) (3).

Ocular severe irritant: (a) A substance that causes tissue damage in the eye following application to the anterior surface of the eye that does not resolve within 21 days of application or causes serious physical decay of vision; (b) Substances that are classified as GHS Category 1, EPA Category I, or EU Category R41 ocular irritants (1) (2) (3).

Opacitometer: An instrument used to measure 'corneal opacity' by quantitatively evaluating light transmission through the cornea. The typical instrument has two compartments, each with its own light source and photocell. One compartment is used for the treated cornea, while the other is used to calibrate and zero the instrument. Light from a halogen lamp is sent through a control compartment (empty chamber without windows or liquid) to a photocell and compared to the light sent through the experimental compartment, which houses the chamber containing the cornea, to a photocell. The difference in light transmission from the photocells is compared and a numeric opacity value is presented on a digital display.

Positive control: A replicate containing all components of a test system and treated with a substance known to induce a positive response. To ensure that variability in the positive control response across time can be assessed, the magnitude of the severe response should not be excessive.

Reliability: Measures of the extent that a test method can be performed reproducibly within and between laboratories over time, when performed using the same protocol. It is assessed by calculating intra- and inter-laboratory reproducibility and intra-laboratory repeatability.

Solvent/vehicle control: An untreated sample containing all components of a test system, including the solvent or vehicle that is processed with the test substance-treated and other control samples to establish the baseline response for the samples treated with the test substance dissolved in the same solvent or vehicle. When tested with a concurrent negative control, this sample also demonstrates whether the solvent or vehicle interacts with the test system.

Tiered testing: A stepwise testing strategy where all existing information on a test substance is reviewed, in a specified order, using a weight of evidence process at each tier to determine if sufficient information is available for a hazard classification decision, prior to progression to the next tier. If the irritancy potential of a test substance can be assigned based on the existing information, no additional testing is required. If the irritancy potential of a test substance cannot be assigned based on the existing information, a step-wise sequential animal testing procedure is performed until an unequivocal classification can be made.

Validated test method: A test method for which validation studies have been completed to determine the relevance (including accuracy) and reliability for a specific purpose. It is important to note that a validated test method may not have sufficient performance in terms of accuracy and reliability to be found acceptable for the proposed purpose.

Weight-of-evidence: The process of considering the strengths and weaknesses of various pieces of information in reaching and supporting a conclusion concerning the hazard potential of a substance.

Appendix 2

Proficiency substances for the BCOP test method

Prior to routine use of a test method that adheres to this test method, laboratories may wish to demonstrate technical proficiency by correctly identifying the ocular corrosivity classification of the 10 substances recommended in Table 1. These substances were selected to represent the range of responses for local eye irritation/corrosion, which is based on results in the *in vivo* rabbit eye test (TG 405) (*i.e.*, Categories 1, 2A, 2B, or Not Classified and Labelled according to the UN GHS (3) (7)). However, considering the validated usefulness of these assays (*i.e.*, to identify ocular corrosives/severe irritants only), there are only two test outcomes for classification purposes (corrosive/severe irritant or non-corrosive/non-severe irritant) to demonstrate proficiency. Other selection criteria were that substances are commercially available, there are high quality *in vivo* reference data available, and there are high quality data from the two *in vitro* methods for which Test Guidelines are being developed. For this reason, irritant substances were selected from the ICCVAM recommended list of 122 reference substances for the validation of *in vitro* ocular toxicity test methods (see Appendix H: ICCVAM Recommended Reference Substances) (5). Reference data are available in the ICCVAM Background Review Documents for BCOP and Isolated Chicken Eye (ICE) test method (17) (18).

Table 1

Recommended substances for demonstrating technical proficiency with BCOP

Substance	CASRN	Chemical Class ⁽¹⁾	Physical Form	<i>In Vivo</i> Classification ⁽²⁾	<i>In Vitro</i> Classification ⁽³⁾
Benzalkonium chloride (5 %)	8001-54-5	Onium compound	Liquid	Category 1	Corrosive/Severe Irritant
Chlorhexidine	55-56-1	Amine, Amidine	Solid	Category 1	Corrosive/Severe Irritant
Dibenzoyl-L-tartaric acid	2743-38-6	Carboxylic acid, Ester	Solid	Category 1	Corrosive/Severe Irritant
Imidazole	288-32-4	Heterocyclic	Solid	Category 1	Corrosive/Severe Irritant
Trichloroacetic acid (30 %)	76-03-9	Carboxylic Acid	Liquid	Category 1	Corrosive/Severe Irritant
2,6-Dichlorobenzoyl chloride	4659-45-4	Acyl halide	Liquid	Category 2A	Non corrosive/Non severe irritant
Ethyl-2-methylacetoacetate	609-14-3	Ketone, Ester	Liquid	Category 2B	Non corrosive/Non severe irritant
Ammonium nitrate	6484-52-2	Inorganic salt	Solid	Category 2A	Non corrosive/Non severe irritant
Glycerol	56-81-5	Alcohol	Liquid	Not Labelled	Non corrosive/Non severe irritant
n-Hexane	110-54-3	Hydrocarbon (acyclic)	Liquid	Not Labeled	Noncorrosive/Non severe irritant

Abbreviations: CASRN = Chemical Abstracts Service Registry Number

⁽¹⁾ Chemical classes were assigned to each test substance using a standard classification scheme, based on the National Library of Medicine Medical Subject Headings (MeSH) classification system (available at <http://www.nlm.nih.gov/mesh>).⁽²⁾ Based on results from the *in vivo* rabbit eye test (OECD TG 405) and using the UN GHS (3)(7).⁽³⁾ Based on results in BCOP and ICE.

Appendix 3

THE BCOP CORNEAL HOLDER

1. The BCOP corneal holders are made of an inert material (e.g., polypropylene). The holders are comprised of two halves (an anterior and posterior chamber), and have two similar cylindrical internal chambers. Each chamber holds a volume of 5 mL and terminates in a glass window, through which opacity measurements are recorded. Each of the inner chambers is 1,7 cm in diameter and 2,2 cm in depth ⁽¹⁾. An o-ring located on the posterior chamber is used to prevent leaks. The corneas are placed endothelial side down on the o-ring of the posterior chambers and the anterior chambers are placed on the epithelial side of the corneas. The chambers are maintained in place by three stainless screws located on the outer edges of the chamber. The end of each chamber houses a glass window which can be removed for easy access to the cornea. An o-ring is also located between the glass window and the chamber to prevent leaks. Two holes on the top of each chamber permit introduction and removal of medium and test compounds. They are closed with rubber caps during the treatment and incubation periods.

⁽¹⁾ The dimensions provided are based on a corneal holder that is used for cows ranging in age from 12 to 60 months old. In the event that animals 6 to 12 months are being used, the holder would instead need to be designed such that each chamber holds a volume of 4 mL, and each of the inner chambers is 1,5 cm in diameter and 2,2 cm in depth. With any newly designed corneal holder, it is very important that the ratio of exposed corneal surface area to posterior chamber volume should be the same as the ratio in the traditional corneal holder. This is necessary to assure that permeability values are correctly determined for the calculation of the IVIS by the proposed formula.

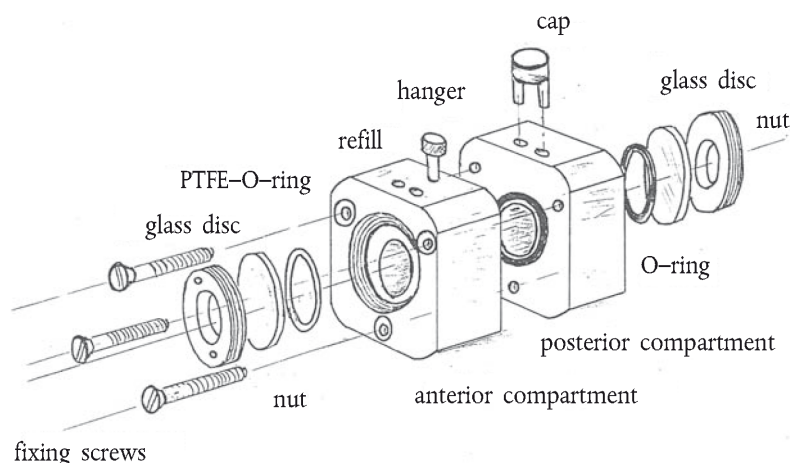

Glossary

Glass disc:

PTFE-O-ring:

Refill:

Hanger:

Cap:

Nut:

O-ring:

Posterior compartment:

Anterior compartment:

Fixing screws:

THE OPACITOMETER

2. The opacitometer is a light transmission measuring device. Light from a halogen lamp is sent through a control compartment (empty chamber without windows or liquid) to a photocell and compared to the light sent through the experimental compartment, which houses the chamber containing the cornea, to a photocell. The difference in light transmission from the photocells is compared and a numeric opacity value is presented on a digital display. The opacity units are established.
3. The opacitometer should provide a linear response through a range of opacity readings covering the cut-offs used for the different classifications described by the Prediction Model (*i.e.*, up to the cut-off determining corrosiveness/severe irritancy). To ensure linear and accurate readings up to 75-80 opacity units, it is necessary to calibrate the opacitometer using a series of calibrators. Calibrators (opaque sheets of polyester) are placed into the calibration chamber (a corneal chamber designed to hold the calibrators) and read on the opacitometer. The calibration chamber is designed to hold the calibrators at approximately the same distance between the light and photocell that the corneas would be placed during the opacity measurements. The opacitometer is first calibrated to 0 opacity units using the calibration chamber without a calibrator. Three different calibrators are then placed into the calibration chamber one by one and the opacities are measured. Calibrators 1, 2 and 3 should result in opacity readings equal to their set values of 75, 150, and 225 opacity units, respectively, $\pm 5\%$.

B. 48. ISOLATED CHICKEN EYE TEST METHOD FOR IDENTIFYING OCULAR CORROSIVES AND SEVERE IRRITANTS

INTRODUCTION

1. The Isolated Chicken Eye (ICE) test method is an *in vitro* test method that can be used, under certain circumstances and with specific limitations, to classify substances and mixtures as ocular corrosives and severe irritants, (1) (2) (3). For the purpose of this test method, severe irritants are defined as those that induce ocular lesions that persist in the rabbit for at least 21 days after administration. While it is not considered valid as a complete replacement for the *in vivo* rabbit eye test, the ICE is recommended for use as part of a tiered testing strategy for regulatory classification and labelling within a specific applicability domain (4) (5). Test substances and mixtures (6) that are positive in this assay can be classified as ocular corrosives or severe irritants without further testing in rabbits. A substance that tests negative would need to be tested in rabbits using a sequential testing strategy, as outlined in OECD Test Guideline 405 (7) (chapter B. 5 of this Annex).
2. The purpose of this test method is to describe the procedures used to evaluate the potential ocular corrosivity or severe irritancy of a test substance as measured by its ability to induce toxicity in an enucleated chicken eye. Toxic effects to the cornea are measured by (i) a qualitative assessment of opacity, (ii) a qualitative assessment of damage to epithelium based on application of fluorescein to the eye (fluorescein retention), (iii) a quantitative measurement of increased thickness (swelling), and (iv) a qualitative evaluation of macroscopic morphological damage to the surface. The corneal opacity, swelling, and damage assessments following exposure to a test substance are assessed individually and then combined to derive an Eye Irritancy Classification.
3. Ocular irritants that induce lesions that resolve in less than 21 days and non-irritants have also been tested using the ICE test method. However, the accuracy and reliability of the ICE test method for substances in these categories have not been formally evaluated.
4. Definitions are provided in Appendix 1.

INITIAL CONSIDERATIONS AND LIMITATIONS

5. This test method is based on the Interagency Coordinating Committee on the Validation of Alternative Methods (ICCVAM) ICE test method protocol (8), which was developed following an international validation study (4) (5) (9), with contributions from the European Centre for the Validation of Alternative Methods, the Japanese Center for the Validation of Alternative Methods, and TNO Quality of Life Department of Toxicology and Applied Pharmacology (Netherlands). The protocol is based on information obtained from published protocols, as well as the current protocol used by TNO (10) (11) (12) (13) (14).
6. The identified limitations for this method are based upon the false positive rate for alcohols and the false negative rates for solids and surfactants (see paragraph 47) (4). When substances within these chemical and physical classes are excluded from the database, the accuracy of ICE across the EU, EPA, and GHS classification systems is substantially improved (4). Based on the purpose of this assay (*i.e.*, to identify ocular corrosives/severe irritants only), false negative rates are not critical since such substances would be subsequently tested in rabbits or with other adequately validated *in vitro* tests, depending on regulatory requirements, using a sequential testing strategy in a weight of evidence approach. Furthermore, the current validation database did not allow for an adequate evaluation of some chemical or product classes (*e.g.*, mixtures). However, investigators could consider using this test method for testing all types of material (including mixtures), whereby a positive result could be accepted as indicative of an ocular corrosive or severe irritant response. However, positive results obtained with alcohols should be interpreted cautiously due to risk of over-prediction.
7. All procedures with chicken eyes should follow the test facility's applicable regulations and procedures for handling of human or animal-derived materials, which include, but are not limited to, tissues and tissue fluids. Universal laboratory precautions are recommended (15).
8. A limitation of the test method is that, although it takes into account some of the ocular effects evaluated in the rabbit ocular irritancy test method and to some degree their severity, it does not consider conjunctival and iridal injuries. Also, although the reversibility of corneal lesions cannot be evaluated *per se* in the ICE test method, it has been proposed, based on rabbit eye studies, that an assessment of the initial depth of corneal injury can be used to distinguish between irreversible and reversible effects (16). Finally, the ICE test method does not allow for an assessment of the potential for systemic toxicity associated with ocular exposure.
9. Efforts are ongoing to further characterize the usefulness and limitations of the ICE test method for identifying non-severe irritants and non-irritants (see also paragraph 48). Users are also encouraged to provide specimens and/or data to validation organizations for a formal evaluation of possible future uses of the ICE test method, including for the identification of non-severe ocular irritants and non-irritants.

10. For any laboratory initially establishing this assay, the proficiency chemicals provided in Appendix 2 should be used. A laboratory can use these chemicals to demonstrate their technical competence in performing the ICE test method prior to submitting ICE data for regulatory hazard classification purposes.

PRINCIPLE OF THE TEST

11. The ICE test method is an organotypic model that provides short-term maintenance of the chicken eye *in vitro*. In this test method, damage by the test substance is assessed by determination of corneal swelling, opacity, and fluorescein retention. While the latter two parameters involve a qualitative assessment, analysis of corneal swelling provides for a quantitative assessment. Each measurement is either converted into a quantitative score used to calculate an overall Irritation Index, or assigned a qualitative categorization that is used to assign an *in vitro* ocular corrosivity and severe irritancy classification. Either of these outcomes can then be used to predict the *in vivo* ocular corrosivity and severe irritation potential of a test substance (see Decision Criteria).

Source and Age of Chicken Eyes

12. Historically, eyes collected from chickens obtained from a slaughterhouse where they are killed for human consumption have been used for this assay, eliminating the need for laboratory animals. Only the eyes of healthy animals considered suitable for entry into the human food chain are used.
13. Although a controlled study to evaluate the optimum chicken age has not been conducted, the age and weight of the chickens used historically in this test method are that of spring chickens traditionally processed by a poultry slaughterhouse (*i.e.*, approximately 7 weeks old, 1,5-2,5 kg).

Collection and Transport of Eyes to the Laboratory

14. Heads should be removed immediately after sedation of the chickens, usually by electric shock, and incision of the neck for bleeding. A local source of chickens close to the laboratory should be located so that their heads can be transferred from the slaughterhouse to the laboratory quickly enough to minimize deterioration and/or bacterial contamination. The time interval between collection of the chicken heads and use of eyes in the ICE test method should be minimized (typically within two hours) and should be demonstrated to not compromise the assay results. These results are based on the selection criteria for the eyes, as well as the positive and negative control responses. All eyes used in the assay should be from the same group of eyes collected on a specific day.
15. Because eyes are dissected in the laboratory, the intact heads are transported from the slaughterhouse at ambient temperature in plastic boxes humidified with towels moistened with isotonic saline.

Selection Criteria for Eyes Used in the ICE

16. Eyes that have high baseline fluorescein staining (*i.e.*, > 0,5) or corneal opacity score (*i.e.*, > 0,5) after they are enucleated are rejected.
17. Each treatment group and concurrent positive control consists of at least three eyes. The negative control group or the solvent control (if using a solvent other than saline) consists of at least one eye.

PROCEDURE

Preparation of the Eyes

18. The eyelids are carefully excised, taking care not to damage the cornea. Corneal integrity is quickly assessed with a drop of 2 % (w/v) sodium fluorescein applied to the corneal surface for a few seconds, and then rinsed with isotonic saline. Fluorescein-treated eyes are then examined with a slit-lamp microscope to ensure that the cornea is undamaged (*i.e.*, fluorescein retention and corneal opacity scores \leq 0,5).
19. If undamaged, the eye is further dissected from the skull, taking care not to damage the cornea. The eyeball is pulled from the orbit by holding the nictitating membrane firmly with surgical forceps, and the eye muscles are cut with a bent, blunt-tipped scissor. It is important to avoid causing corneal damage due to excessive pressure (*i.e.*, compression artifacts).
20. When the eye is removed from the orbit, a visible portion of the optic nerve should be left attached. Once removed from the orbit, the eye is placed on an absorbent pad and the nictitating membrane and other connective tissue are cut away.

21. The enucleated eye is mounted in a stainless steel clamp with the cornea positioned vertically. The clamp is then transferred to a chamber of the superfusion apparatus (16). The clamps should be positioned in the superfusion apparatus such that the entire cornea is supplied with the isotonic saline drip. The chambers of the superfusion apparatus should be temperature controlled at $32 \pm 1,5$ °C. Appendix 3 provides a diagram of a typical superfusion apparatus and the eye clamps, which can be obtained commercially or constructed. The apparatus can be modified to meet the needs of an individual laboratory (e.g., to accommodate a different number of eyes).
22. After being placed in the superfusion apparatus, the eyes are again examined with a slit-lamp microscope to ensure that they have not been damaged during the dissection procedure. Corneal thickness should also be measured at this time at the corneal apex using the depth measuring device on the slit-lamp microscope. Eyes with; (i), a fluorescein retention score of $> 0,5$; (ii) corneal opacity $> 0,5$; or, (iii), any additional signs of damage should be replaced. For eyes that are not rejected based on any of these criteria, individual eyes with a corneal thickness deviating more than 10 % from the mean value for all eyes are to be rejected. Users should be aware that slit-lamp microscopes could yield different corneal thickness measurements if the slit-width setting is different. The slit-width should be set at 0,095 mm.
23. Once all eyes have been examined and approved, the eyes are incubated for approximately 45 to 60 minutes to equilibrate them to the test system prior to dosing. Following the equilibration period, a zero reference measurement is recorded for corneal thickness and opacity to serve as a baseline (i.e., time = 0). The fluorescein score determined at dissection is used as the baseline measurement for that endpoint.

Application of the Test Substance

24. Immediately following the zero reference measurements, the eye (in its holder) is removed from the superfusion apparatus, placed in a horizontal position, and the test substance is applied to the cornea.
25. Liquid test substances are typically tested undiluted, but may be diluted if deemed necessary (e.g., as part of the study design). The preferred solvent for diluted substances is physiological saline. However, alternative solvents may also be used under controlled conditions, but the appropriateness of solvents other than physiological saline should be demonstrated.
26. Liquid test substances are applied to the cornea such that the entire surface of the cornea is evenly covered with the test substance; the standard volume is 0,03 mL.
27. If possible, solid substances should be ground as finely as possible in a mortar and pestle, or comparable grinding tool. The powder is applied to the cornea such that the surface is uniformly covered with the test substance; the standard amount is 0,03 g.
28. The test substance (liquid or solid) is applied for 10 seconds and then rinsed from the eye with isotonic saline (approximately 20 mL) at ambient temperature. The eye (in its holder) is subsequently returned to the superfusion apparatus in the original upright position.

Control Substances

29. Concurrent negative or solvent/vehicle controls and positive controls should be included in each experiment.
30. When testing liquids at 100 % or solids, physiological saline is used as the concurrent negative control in the ICE test method to detect non-specific changes in the test system, and to ensure that the assay conditions do not inappropriately result in an irritant response.
31. When testing diluted liquids, a concurrent solvent/vehicle control group is included in the test method to detect non-specific changes in the test system, and to ensure that the assay conditions do not inappropriately result in an irritant response. As stated in paragraph 25, only a solvent/vehicle that has been demonstrated to have no adverse effects on the test system can be used.

32. A known ocular irritant is included as a concurrent positive control in each experiment to verify that an appropriate response is induced. As the ICE assay is being used in this test method to identify corrosive or severe irritants, the positive control should be a reference substance that induces a severe response in this test method. However, to ensure that variability in the positive control response across time can be assessed, the magnitude of the severe response should not be excessive. Sufficient *in vitro* data for the positive control should be generated such that a statistically defined acceptable range for the positive control can be calculated. If adequate historical ICE test method data are not available for a particular positive control, studies may need to be conducted to provide this information.
33. Examples of positive controls for liquid test substances are 10 % acetic acid or 5 % benzalkonium chloride, while examples of positive controls for solid test substances are sodium hydroxide or imidazole.
34. Benchmark substances are useful for evaluating the ocular irritancy potential of unknown chemicals of a specific chemical or product class, or for evaluating the relative irritancy potential of an ocular irritant within a specific range of irritant responses.

Endpoints Measured

35. Treated corneas are evaluated pretreatment and starting at 30, 75, 120, 180, and 240 minutes (\pm 5 minutes) after the post-treatment rinse. These time points provide an adequate number of measurements over the four-hour treatment period, while leaving sufficient time between measurements for the requisite observations to be made for all eyes.
36. The endpoints evaluated are corneal opacity, swelling, fluorescein retention, and morphological effects (*e.g.*, pitting or loosening of the epithelium). All of the endpoints, with the exception of fluorescein retention (which is determined only at pretreatment and 30 minutes after test substance exposure) are determined at each of the above time points.
37. Photographs are advisable to document corneal opacity, fluorescein retention, morphological effects and, if conducted, histopathology
38. After the final examination at four hours, users are encouraged to preserve eyes in an appropriate fixative (*e.g.*, neutral buffered formalin) for possible histopathological examination.
39. Corneal swelling is determined from corneal thickness measurements made with an optical pachymeter on a slit-lamp microscope. It is expressed as a percentage and is calculated from corneal thickness measurements according to the following formula:

$$\left(\frac{\text{corneal thickness at time } t - \text{corneal thickness at time } = 0}{\text{corneal thickness at time } = 0} \right) \times 100$$

40. The mean percentage of corneal swelling for all test eyes is calculated for all observation time points. Based on the highest mean score for corneal swelling, as observed at any time point, an overall category score is then given for each test substance.
41. Corneal opacity is calculated by using the area of the cornea that is most densely opacified for scoring. The mean corneal opacity value for all test eyes is calculated for all observation time points. Based on the highest mean score for corneal opacity, as observed at any time point, an overall category score is then given for each test substance (Table 1).

Table 1
Corneal opacity scores

Score	Observation
0	No opacity
0,5	Very faint opacity

Score	Observation
1	Scattered or diffuse areas; details of the iris are clearly visible
2	Easily discernible translucent area; details of the iris are slightly obscured
3	Severe corneal opacity; no specific details of the iris are visible; size of the pupil is barely discernible
4	Complete corneal opacity; iris invisible

42. The mean fluorescein retention value for all test eyes is calculated for the 30-minute observation time point only, which is used for the overall category score given for each test substance (Table 2).

Table 2
Fluorescein retention scores

Score	Observation
0	No fluorescein retention
0,5	Very minor single cell staining
1	Single cell staining scattered throughout the treated area of the cornea
2	Focal or confluent dense single cell staining
3	Confluent large areas of the cornea retaining fluorescein

43. Morphological effects include “pitting” of corneal epithelial cells, “loosening” of epithelium, “roughening” of the corneal surface and “sticking” of the test substance to the cornea. These findings can vary in severity and may occur simultaneously. The classification of these findings is subjective according to the interpretation of the investigator.

DATA AND REPORTING

Data Evaluation

44. Results from corneal opacity, swelling, and fluorescein retention should be evaluated separately to generate an ICE class for each endpoint. The ICE classes for each endpoint are then combined to generate an Irritancy Classification for each test substance.

Decision Criteria

45. Once each endpoint has been evaluated, ICE classes can be assigned based on a predetermined range. Interpretation of corneal thickness (Table 3), opacity (Table 4), and fluorescein retention (Table 5) using four ICE classes is done according to the following scales:

Table 3
ICE classification criteria for corneal thickness

Mean Corneal Swelling (%) (*)	ICE Class
0 to 5	I
> 5 to 12	II
> 12 to 18 (> 75 min after treatment)	II
> 12 to 18 (≤ 75 min after treatment)	III
> 18 to 26	III

Mean Corneal Swelling (%) (*)	ICE Class
> 26 to 32 (> 75 min after treatment)	III
> 26 to 32 (≤ 75 min after treatment)	IV
> 32	IV

(*) Corneal swelling scores only applicable if thickness is measured with a Haag-Streit BP900 slit-lamp microscope with depth-measuring device No I and slit-width setting at 9½, equaling 0,095 mm. Users should be aware that slit-lamp microscopes could yield different corneal thickness measurements if the slit-width setting is different.

Table 4

ICE classification criteria for opacity

Mean Maximum Opacity Score (*)	ICE Class
0,0-0,5	I
0,6-1,5	II
1,6-2,5	III
2,6-4,0	IV

(*) See Table 1.

Table 5

ICE classification criteria for mean fluorescein retention

Mean Fluorescein Retention Score at 30 minutes post-treatment (*)	ICE Class
0,0-0,5	I
0,6-1,5	II
1,6-2,5	III
2,6-3,0	IV

(*) See Table 2.

46. The overall *in vitro* irritancy classification for a test substance is assessed by reading the irritancy classification that corresponds to the combination of categories obtained for corneal swelling, corneal opacity, and fluorescein retention and applying the scheme presented in Table 6.

Table 6

Overall *in vitro* irritancy classifications

Classification	Combinations of the 3 Endpoints
Corrosive/Severe Irritant	3 × IV 2 × IV, 1 × III 2 × IV, 1 × II (*) 2 × IV, 1 × I (*) Corneal opacity ≥ 3 at 30 min (in at least 2 eyes) Corneal opacity = 4 at any time point (in at least 2 eyes) Severe loosening of the epithelium (in at least 1 eye)

(*) Combinations less likely to occur.

47. As stated in paragraph 1, if the test substance is not identified as an ocular corrosive or severe irritant, additional testing should be conducted for classification and labelling purposes. The ICE test method has an overall accuracy of 83 % (120/144) to 87 % (134/154), a false positive rate of 6 % (7/122) to 8 % (9/116), and a false negative rate of 41 % (13/32) to 50 % (15/30) for the identification of ocular corrosives and severe irritants, when compared to *in vivo* rabbit eye test method data classified according to the EPA (1), EU (2), or GHS (3) classification systems. When substances within certain chemical (*i.e.*, alcohols and surfactants) and physical (*i.e.*, solids) classes are excluded from the database, the accuracy of ICE across the EU, EPA, and GHS classification systems ranges from 91 % (75/82) to 92 % (69/75), the false positive rates range from 5 % (4/73) to 6 % (4/70), and the false negative rates range from 29 % (2/7) to 33 % (3/9) (4).
48. Even if an ocular corrosive or severe irritant classification is not obtained for a test substance, ICE data can be useful in conjunction with test data from the *in vivo* rabbit eye test or from an adequately validated *in vitro* test to further evaluate the usefulness and limitations of the ICE test method for identifying non-severe irritants and non-irritants (a Guidance Document on the use of *in vitro* ocular toxicity test methods is under development).

Study Acceptance Criteria

49. A test is considered acceptable if the concurrent negative or vehicle/solvent controls and the concurrent positive controls give an Irritancy Classification that falls within nonirritant and severe irritant/corrosive classes, respectively.

Test Report

50. The test report should include the following information, if relevant to the conduct of the study:

Test and Control Substances

Chemical name(s) such as the structural name used by the Chemical Abstracts Service (CAS), followed by other names, if known;

The CAS Registry Number (RN), if known;

Purity and composition of the substance or mixture (in percentage(s) by weight), to the extent this information is available;

Physicochemical properties such as physical state, volatility, pH, stability, chemical class water solubility relevant to the conduct of the study;

Treatment of the test/control substances prior to testing, if applicable (*e.g.*, warming, grinding);

Stability, if known;

Information Concerning the Sponsor and the Test Facility

Name and address of the sponsor, test facility and study director;

Identification on the source of the eyes (*e.g.*, the facility from which they were collected);

Storage and transport conditions of eyes (*e.g.*, date and time of eye collection, time interval prior to initiating testing);

If available, specific characteristics of the animals from which the eyes were collected (*e.g.*, age, sex, weight of the donor animal);

Justification of the Test Method and Protocol Used

Test Method Integrity

The procedure used to ensure the integrity (*i.e.*, accuracy and reliability) of the test method over time (*e.g.*, periodic testing of proficiency substances, use of historical negative and positive control data).

Criteria for an Acceptable Test

If applicable, acceptable concurrent benchmark control ranges based on historical data;

Test Conditions

Description of test system used;

Slit-lamp microscope used (e.g., model);

Instrument settings for the slit-lamp microscope used;

Information for the chicken eyes used, including statements regarding their quality;

Details of test procedure used;

Test substance concentration(s) used;

Description of any modifications of the test procedure;

Reference to historical data of the model (e.g., negative and positive controls, proficiency substances, benchmark substances);

Description of evaluation criteria used;

Results

Description of other effects observed;

If appropriate, photographs of the eye;

Discussion of the Results

Conclusion

LITERATURE

- (1) U.S. EPA (1996). Label Review Manual: 2nd Edition. EPA737-B-96-001. Washington, DC: U.S. Environmental Protection Agency.
- (2) Regulation (EC) No 1272/2008 of the European Parliament and of the Council of 16 December 2008 on classification, labelling and packaging of substances and mixtures, amending and repealing Directive 67/548/EEC and 1999/45/EC, and amending Regulation (EC) No 1907/2006. OJ L 353, 31.12.2008, p. 1.
- (3) United nations (UN) (2007). Globally Harmonized System of Classification and Labelling of Chemicals (GHS), Second revised edition, UN New York and Geneva, 2007. Available at:

[http://www.unece.org/trans/danger/publi/ghs/ghs_rev02/02files_e.html]
- (4) ICCVAM (2007). Test Method Evaluation Report - *In Vitro Ocular Toxicity* Test Methods for Identifying Ocular Severe Irritants and Corrosives. Interagency Coordinating Committee on the Validation of Alternative Methods (ICCVAM) and the National Toxicology Program (NTP) Interagency Center for the Evaluation of Alternative Toxicological Methods (NICEATM). NIH Publication No: 07-4517. Available:

[http://iccvam.niehs.nih.gov/methods/ocutox/ivocutox/ocu_tmer.htm]
- (5) ESAC (2007). Statement on the conclusion of the ICCVAM retrospective study on organotypic *in vitro* assays as screening tests to identify potential ocular corrosives and severe eye irritants. Available:

[<http://ecvam.jrc.it/index.htm>].

- (6) Regulation (EC) No 1907/2006 of the European Parliament and of the Council of 18 December 2006 concerning the Registration, Evaluation, Authorisation and Restriction of Chemicals (REACH), establishing a European Chemicals Agency, amending Directive 1999/45/EC and repealing Council Regulation (EEC) No 793/93 and Commission Regulation (EC) No 1488/94 as well as Council Directive 76/769/EEC and Commission Directives 91/155/EEC, 93/67/EEC, 93/105/EC and 2000/21/EC. OJ L 396, 30.12.2006, p. 1.
- (7) OECD (2002). Test Guideline 405. OECD Guideline for Testing of Chemicals. Acute eye irritation/corrosion. Available:
[\[http://www.oecd.org/document/40/0,2340,en_2649_34377_37051368_1_1_1_1,00.html\]](http://www.oecd.org/document/40/0,2340,en_2649_34377_37051368_1_1_1_1,00.html)
- (8) ICCVAM (2007). ICCVAM Recommended ICE Test Method Protocol. In: ICCVAM Test Method Evaluation Report - *In Vitro* Ocular Toxicity Test Methods for Identifying Ocular Severe Irritants and Corrosives. Inter-agency Coordinating Committee on the Validation of Alternative Methods (ICCVAM) and the National Toxicology Program (NTP) Interagency Center for the Evaluation of Alternative Toxicological Methods (NICEATM). NIH Publication No: 07-4517. Available:
[\[http://iccvam.niehs.nih.gov/methods/ocutox/ivocutox/ocu_tmer.htm\]](http://iccvam.niehs.nih.gov/methods/ocutox/ivocutox/ocu_tmer.htm)
- (9) ICCVAM. (2006). Current Status of *In Vitro* Test Methods for Identifying Ocular Corrosives and Severe Irritants: Isolated Chicken Eye Test Method. NIH Publication No: 06-4513. Research Triangle Park: National Toxicology Program. Available:
[\[http://iccvam.niehs.nih.gov/methods/ocutox/ivocutox/ocu_brd_ice.htm\]](http://iccvam.niehs.nih.gov/methods/ocutox/ivocutox/ocu_brd_ice.htm)
- (10) Prinsen, M.K. and Koëter, B.W.M. (1993). Justification of the enucleated eye test with eyes of slaughterhouse animals as an alternative to the Draize eye irritation test with rabbits. *Fd. Chem. Toxicol.* 31:69-76.
- (11) INVITTOX (1994). Protocol 80: Chicken enucleated eye test (CEET). Available:
[\[http://ecvam.jrc.it/index.htm\]](http://ecvam.jrc.it/index.htm)
- (12) Balls, M., Botham, P.A., Bruner, L.H. and Spielmann H. (1995). The EC/HO international validation study on alternatives to the Draize eye irritation test. *Toxicol. In Vitro* 9:871-929.
- (13) Prinsen, M.K. (1996). The chicken enucleated eye test (CEET): A practical (pre)screen for the assessment of eye irritation/corrosion potential of test materials. *Food Chem. Toxicol.* 34:291-296.
- (14) Chamberlain, M., Gad, S.C., Gautheron, P. and Prinsen, M.K. (1997). IRAG Working Group I: Organotypic models for the assessment/prediction of ocular irritation. *Food Chem. Toxicol.* 35:23-37.
- (15) Siegel, J.D., Rhinehart, E., Jackson, M., Chiarello, L., and the Healthcare Infection Control Practices Advisory Committee (2007). Guideline for Isolation Precautions: Preventing Transmission of Infectious Agents in Healthcare Settings. Available:
[\[http://www.cdc.gov/ncidod/dhqp/pdf/isolation2007.pdf\]](http://www.cdc.gov/ncidod/dhqp/pdf/isolation2007.pdf).
- (16) Maurer, J.K., Parker, R.D. and Jester J.V. (2002). Extent of corneal injury as the mechanistic basis for ocular irritation: key findings and recommendations for the development of alternative assays. *Reg. Tox. Pharmacol.* 36:106-117.
- (17) Burton, A.B.G., M. York and R.S. Lawrence (1981). The *in vitro* assessment of severe irritants. *Fd. Cosmet.-Toxicol.* 19, 471-480.
- (18) ICCVAM (2006). Background review document, Current Status of *In Vitro* Test Methods for Identifying Ocular Corrosives and Severe Irritants: Bovine Corneal Opacity and Permeability (BCOP) Test Method. Available:
[\[http://iccvam.niehs.nih.gov/methods/ocutox/ivocutox/ocu_brd_bcop.htm\]](http://iccvam.niehs.nih.gov/methods/ocutox/ivocutox/ocu_brd_bcop.htm)
- (19) ICCVAM (2006). Background review document, Current Status of *In Vitro* Test Methods for Identifying Ocular Corrosives and Severe Irritants Isolated Chicken Eye (ICE) Test Method. Available:
[\[http://iccvam.niehs.nih.gov/methods/ocutox/ivocutox/ocu_brd_bcop.htm\]](http://iccvam.niehs.nih.gov/methods/ocutox/ivocutox/ocu_brd_bcop.htm)
-

Appendix 1

DEFINITIONS

Accuracy: The closeness of agreement between test method results and accepted reference values. It is a measure of test method performance and one aspect of 'relevance'. The term is often used interchangeably with 'concordance', to mean the proportion of correct outcomes of a test method.

Benchmark substance: A substance used as a standard for comparison to a test substance. A benchmark substance should have the following properties; (i), a consistent and reliable source(s); (ii), structural and functional similarity to the class of substances being tested; (iii), known physical/chemical characteristics; (iv), supporting data on known effects; and (v), known potency in the range of the desired response

Cornea: The transparent part of the front of the eyeball that covers the iris and pupil and admits light to the interior.

Corneal opacity: Measurement of the extent of opaqueness of the cornea following exposure to a test substance. Increased corneal opacity is indicative of damage to the cornea.

Corneal swelling: An objective measurement in the ICE test of the extent of distention of the cornea following exposure to a test substance. It is expressed as a percentage and is calculated from baseline (pre-dose) corneal thickness measurements and the thickness recorded at regular intervals after exposure to the test material in the ICE test. The degree of corneal swelling is indicative of damage to the cornea.

EPA Category 1: Corrosive (irreversible destruction of ocular tissue) or corneal involvement or irritation persisting for more than 21 days (1).

EU Category R41: Production of tissue damage in the eye, or serious physical decay of vision, following application of a test substance to the anterior surface of the eye, which is not fully reversible within 21 days of application (2).

False negative rate: The proportion of all positive substances falsely identified by a test method as negative. It is one indicator of test method performance.

False positive rate: The proportion of all negative substances that are falsely identified by a test method as positive. It is one indicator of test method performance.

Fluorescein retention: A subjective measurement in the ICE test of the extent of fluorescein sodium that is retained by epithelial cells in the cornea following exposure to a test substance. The degree of fluorescein retention is indicative of damage to the corneal epithelium.

GHS (Globally Harmonized System of Classification and Labelling of Chemicals): A system proposing the classification of chemicals (substances and mixtures) according to standardized types and levels of physical, health and environmental hazards, and addressing corresponding communication elements, such as pictograms, signal words, hazard statements, precautionary statements and safety data sheets, so that to convey information on their adverse effects with a view to protect people (including employers, workers, transporters, consumers and emergency responders) and the environment (3).

GHS Category 1: Production of tissue damage in the eye, or serious physical decay of vision, following application of a test substance to the anterior surface of the eye, which is not fully reversible within 21 days of application (3).

Hazard: Inherent property of an agent or situation having the potential to cause adverse effects when an organism, system or (sub) population is exposed to that agent.

Negative control: An untreated replicate containing all components of a test system. This sample is processed with test substance-treated samples and other control samples to determine whether the solvent interacts with the test system.

Non-irritant: Substances that are not classified as EPA Category I, II, or III; EU Category R41 or R36; or GHS Category 1, 2A, or 2B ocular irritants (1)(2)(3).

Ocular corrosive: (a) A substance that causes irreversible tissue damage to the eye. (b) Substances that are classified as GHS Category 1, EPA Category I, or EU Category R41 ocular irritants (1)(2)(3).

Ocular irritant: (a) A substance that produces a reversible change in the eye following application to the anterior surface of the eye; (b) Substances that are classified as EPA Category II or III; EU Category R36; or GHS Category 2A, or 2B ocular irritants (1)(2)(3).

Ocular severe irritant: (a) A substance that causes tissue damage in the eye following application to the anterior surface of the eye that is not reversible within 21 days of application or causes serious physical decay of vision. (b) Substances that are classified as GHS Category 1, EPA Category I, or EU Category R41 ocular irritants (1)(2)(3).

Positive control: A replicate containing all components of a test system and treated with a substance known to induce a positive response. To ensure that variability in the positive control response across time can be assessed, the magnitude of the severe response should not be excessive.

Reliability: Measures of the extent that a test method can be performed reproducibly within and between laboratories over time, when performed using the same protocol. It is assessed by calculating intra- and inter-laboratory reproducibility and intra-laboratory repeatability.

Slit-lamp microscope: An instrument used to directly examine the eye under the magnification of a binocular microscope by creating a stereoscopic, erect image. In the ICE test method, this instrument is used to view the anterior structures of the chicken eye as well as to objectively measure corneal thickness with a depth-measuring device attachment.

Solvent/vehicle control: An untreated sample containing all components of a test system, including the solvent or vehicle that is processed with the test substance-treated and other control samples to establish the baseline response for the samples treated with the test substance dissolved in the same solvent or vehicle. When tested with a concurrent negative control, this sample also demonstrates whether the solvent or vehicle interacts with the test system.

Tiered testing: A stepwise testing strategy where all existing information on a test substance is reviewed, in a specified order, using a weight of evidence process at each tier to determine if sufficient information is available for a hazard classification decision, prior to progression to the next tier. If the irritancy potential of a test substance can be assigned based on the existing information, no additional testing is required. If the irritancy potential of a test substance cannot be assigned based on the existing information, a step-wise sequential animal testing procedure is performed until an unequivocal classification can be made.

Validated test method: A test method for which validation studies have been completed to determine the relevance (including accuracy) and reliability for a specific purpose. It is important to note that a validated test method may not have sufficient performance in terms of accuracy and reliability to be found acceptable for the proposed purpose.

Weight-of-evidence: The process of considering the strengths and weaknesses of various pieces of information in reaching and supporting a conclusion concerning the hazard potential of a substance.

Appendix 2

PROFICIENCY CHEMICALS FOR THE ICE TEST METHOD

Prior to routine use of a test method that adheres to this test method, laboratories may wish to demonstrate technical proficiency by correctly identifying the ocular corrosivity classification of the 10 substances recommended in Table 1. These substances were selected to represent the range of responses for local eye irritation/corrosion, which is based on results in the *in vivo* rabbit eye test (TG 405) (i.e., Categories 1, 2A, 2B, or Not Classified or Labeled according to the UN GHS)(3)(7). However, considering the validated usefulness of these assays (i.e., to identify ocular corrosives/severe irritants only), there are only two test outcomes for classification purposes (corrosive/severe irritant or non-corrosive/non-severe irritant) to demonstrate proficiency. Other selection criteria were that substances are commercially available, there are high quality *in vivo* reference data available, and there are high quality data from the two *in vitro* methods for which Test Guidelines are being developed. For this reason, irritant substances were selected from the ICCVAM recommended list of 122 reference substances for the validation of *in vitro* ocular toxicity test methods (see Appendix H, ICCVAM Recommended Reference Substances List)(4). Reference data are available in the ICCVAM Background Review Documents for the Bovine Corneal Opacity and Permeability (BCOP) and the ICE test methods (18) (19).

Table 1

Recommended substances for demonstrating technical proficiency with ICE

Chemical	CASRN	Chemical Class ⁽¹⁾	Physical Form	<i>In Vivo</i> Classification ⁽²⁾	<i>In Vitro</i> Classification ⁽³⁾
Benzalkonium chloride (5 %)	8001-54-5	Onium compound	Liquid	Category 1	Corrosive/Severe Irritant
Chlorhexidine	55-56-1	Amine, Amidine	Solid	Category 1	Corrosive/Severe Irritant
Dibenzoyl-L-tartaric acid	2743-38-6	Carboxylic acid, Ester	Solid	Category 1	Corrosive/Severe Irritant
Imidazole	288-32-4	Heterocyclic	Solid	Category 1	Corrosive/Severe Irritant
Trichloroacetic acid (30 %)	76-03-9	Carboxylic Acid	Liquid	Category 1	Corrosive/Severe Irritant
2,6-Dichlorobenzoyl chloride	4659-45-4	Acyl halide	Liquid	Category 2A	Non-corrosive/Non-severe irritant
Ethyl-2-methylacetate	609-14-3	Ketone, Ester	Liquid	Category 2B	Non-corrosive/Non-severe irritant
Ammonium nitrate	6484-52-2	Inorganic salt	Solid	Category 2A	Non-corrosive/Non-severe irritant
Glycerol	56-81-5	Alcohol	Liquid	Not Labeled	Non-corrosive/Non-severe irritant
n-Hexane	110-54-3	Hydrocarbon (acyclic)	Liquid	Not Labeled	Non-corrosive/Non-severe irritant

Abbreviations: CASRN = Chemical Abstracts Service Registry Number

⁽¹⁾ Chemical classes were assigned to each test substance using a standard classification scheme, based on the National Library of Medicine Medical Subject Headings (MeSH) classification system (available at <http://www.nlm.nih.gov/mesh>).

⁽²⁾ Based on results from the *in vivo* rabbit eye test (OECD TG 405) and using the UN GHS (3)(7).

⁽³⁾ Based on results in BCOP and ICE.

Appendix 3

Diagrams of the ICE superfusion apparatus and eye clamps

(See Burton et al. (17) for additional generic descriptions of the superfusion apparatus and eye clamp)

